

kanth



**K200-C-(R)**

**Round Ceiling Mounted Overhead Shower**

**INSTALLATION INSTRUCTIONS**

Thank you for purchasing a Kanth Overhead Shower. We are confident that this product, if installed correctly, will give you many years of trouble free showering. In the event of any problems please contact us at [support@kanth.london](mailto:support@kanth.london).

IT IS RECOMMENDED THAT THE INSTALLATION IS CARRIED OUT BY A QUALIFIED PLUMBER.

PLEASE READ THESE INSTRUCTIONS CAREFULLY BEFORE FITTING.

## IMPORTANT

Please keep these instructions after installation, you will need the product reference information set out on the back page in order to validate and/or make a claim regarding the product guarantee.

## CEILING MOUNTED DIMENSIONS

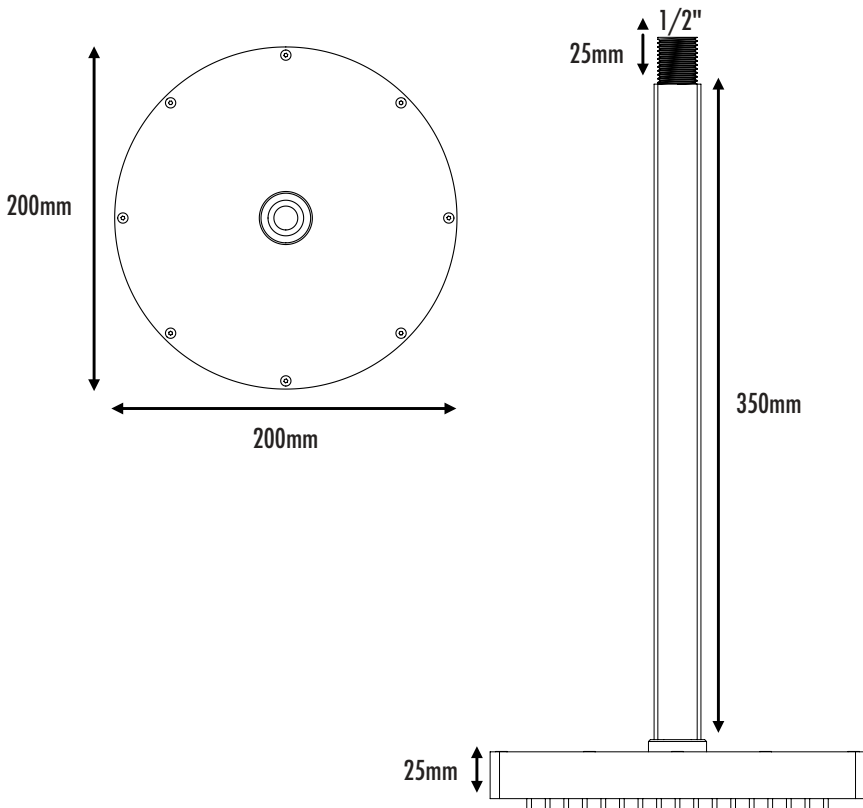

## CEILING ARM ASSEMBLY

---

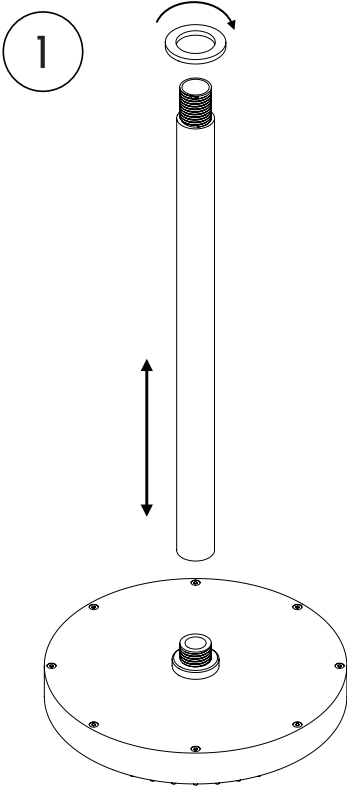

### Step One:

Assemble the ceiling mounted shower by first applying PTFE tape or your preferred method of thread sealant to the 1/2" BSP threaded section on the back of the shower head. Second screw the arm onto the shower head in a clockwise motion until the arm will not rotate further. Then place the cover plate over the arm ready to be fixed to the ceiling

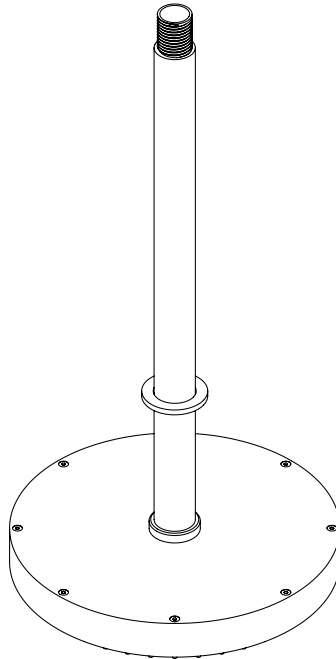

## INSTALLING THE CEILING MOUNTED OVERHEAD SHOWER

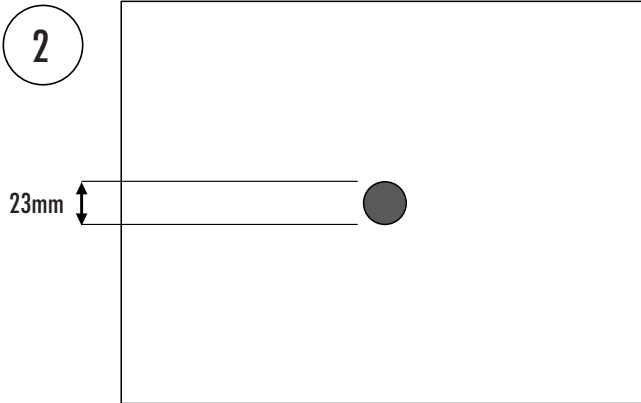

Step Two:  
Begin by cutting a hole in your ceiling in line with the 1/2" BSP connector which is 23mm, this is where the threaded section of the shower arm will enter

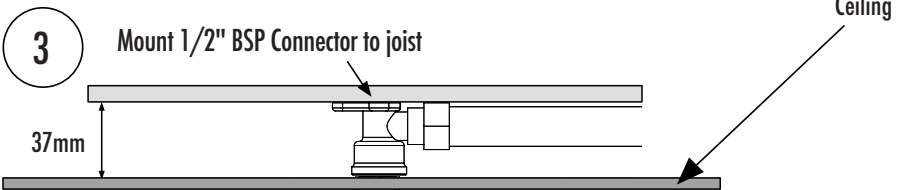

Step Three:  
Secure the 1/2" BSP connector to the joist and leave a 37mm gap. Apply PTFE tape or your preferred method of thread sealant to the 1/2" BSP threaded section at the end of the shower arm, and align with the 1/2" BSP connector in the ceiling. Screw the ceiling mounted overhead shower into the connector turning the shower arm only

**(PLEASE ENSURE YOU SCREW IN USING THE ARM NOT THE SHOWER HEAD TO PREVENT IT SHEARING)**

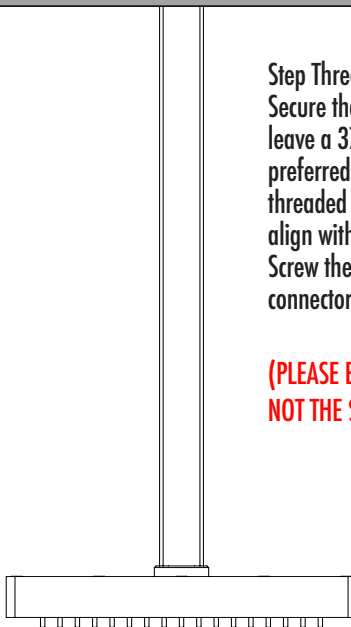

## INSTALLING THE CEILING MOUNTED OVERHEAD SHOWER

---

4



**Step Four:**  
Finally seal the back plate to the ceiling  
using the adhesive of your choice

## FULLY INSTALLED VIEW

---

5

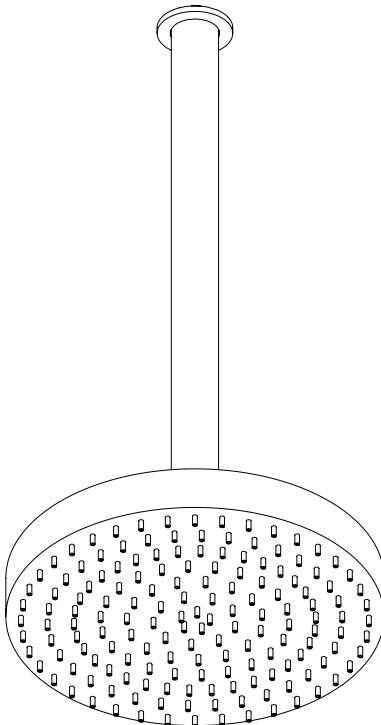

## CLEANING INSTRUCTIONS

---

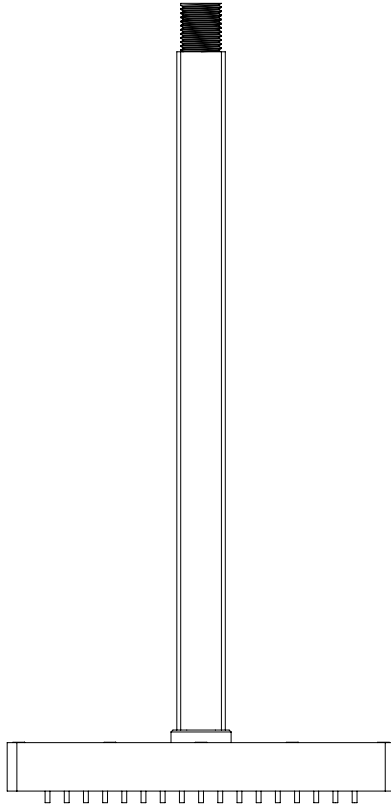

Lightly brush the nozzles of your Overhead Shower once a week with a cloth in order to prevent any limescale build up in the nozzles

## KANTH GUARANTEE

---

### Product Body and Backplate – 25 Year Guarantee

We guarantee the brass body and backplate against defects in workmanship and raw material for a period of 25-years. Within the guarantee period we will resolve defects by repairing or replacing defect components free of charge. As our products are designed to last longer than you may be staying in your house, we will allow all customers who register their product with us to transfer the guarantee to the new owners of their property.

### Consumable Components – 12.½ Year Guarantee

Your product will be affected by general wear and tear through daily use. As with any products there will a requirement to replace consumable parts periodically dependent on frequency of use and how the product is maintained. All consumable components are guaranteed for a period of 12.½ years or half the lifetime of the product and we will keep a full stock of all parts for the life of the product. Consumable Components include;

Gasket	Seals
--------	-------

### Consumable Components Extended Lifetime Guarantee

In addition to the standard 12.½ year guarantee provided on the consumable components, we offer an extended guarantee which will cover your product for the full 25-year lifetime, at a one-off low cost. This extended guarantee can be purchased when registering your product or at a later date. For further information on how to extend the guarantee please visit [www.kanth.london](http://www.kanth.london).

## MAINTENANCE AND CLEANING

---

The brass body should be cleaned frequently by wiping with a damp soft cloth and polished with a dry duster. Cleaners containing alcohol, acid or corrosive materials should not be used.

Do not use abrasive cleaners, detergents or polishes, this will cause harm to the finish of your product and void the guarantee.

Visit [www.kanth.london](http://www.kanth.london) for more guidance on maintenance & cleaning.

## REFRESH SCHEME

---

To ensure the longevity and sustainability of our products we offer our Refresh Scheme. It is designed to support our customers for the duration of our products' lifetime, maintaining the performance and look of the product while also allowing adaptations to account for new tastes. Not only this but it brings down the cost of ownership, making our products both luxury and outstanding value. Our Refresh Scheme offers two simple options:

The first is renew- our product is designed to last for at least 25 years, but we know many homeowners look to refresh their bathroom every five to six years. So, when you replace your tiles and fittings you return the product to our UK factory for renewal. We'll either refresh the current finish or plate the set in an alternative finish which matches your new bathroom.

Secondly, if you decide to replace your Kanth product with a different style, then we can exchange your original product and offset the cost against your new choice. And don't worry, your returned product won't go to waste - we will renew it and put it back into our stock.

We are constantly improving and simplifying our processes, for full up to date details on our Refresh Scheme please visit [www.kanth.london](http://www.kanth.london) or contact us by email or phone as detailed below.

### Replacement Parts

As part of our sustainability policy we reserve the right to replace any faulty component with a new or renewed replacement, on the provision that there will be no likelihood detriment to the function of the supplied component. Any replacement parts are guaranteed until the expiry of the original guarantee.

### Guide to a Full and Long Life

Customers often look to replace components long before they require replacing. This is sometimes due to misdiagnosis of fault, speed of repair, or incorrect installation. At Kanth we always recommend in the first instance reading our troubleshooting guide at [www.kanth.london](http://www.kanth.london) or contacting our customer service team, details below.

## FINISHES

---

We use the best materials, processes and skilled labour to ensure the highest standard of finishes to our products. Depending on the finish, products may vary in coloration and effect. We endeavour to minimise and ensure assembled items match as far as possible. Each finish is subject to its own guarantee period due to the nature of the finish, these include;

Polished Chrome	5 years
Polished/Brushed Nickel	2 years
Lacquered Special Finishes*	2 years
Unlacquered Polished/Brushed Brass**	No Guarantee

Special Finishes – Our special finishes are created by hand, by skilled metal finishers. We apply unique processes which alter the appearance of the raw material surface through a combination of polishing, brushing and chemicals. Each piece will be unique and vary slightly in appearance adding to the beauty of each product.

\*Lacquered Finishes - As standard we supply any Special Finish with a lacquered coating. We have spent many years researching and developing our lacquer coating to provide a hard durable surface, which combines our products aesthetic beauty with longevity. However, like all surfaces this lacquer can be degraded through the use of harsh chemicals and abrasives. If your products are treated well and maintained as per the instructions you will have many years of unblemished use.

\*\*Unlacquered Finishes – all of our products are manufactured from solid brass ingots, and as such, when left unprotected they will age, tarnish and change in appearance over time – this is often referred to as a living finish. Aged brass can be wonderful in appearance and offer a very unique and individual finish. We have no control over living finish products and as such can offer no guarantee to their appearance after supply.

For a full list our finishes and their guarantee periods visit [www.kanth.london](http://www.kanth.london).

Please note; Any claim for a faulty finish will only be successful if all products have been maintained and cleaned as per the guidance stated, failure to do so will void this guarantee period.

## LIMITATIONS AND EXCLUSIONS

---

This guarantee does not cover damage or defects arising as a result of:

Non-domestic use	Misuse	Careless handling
Incorrect installation	Wilful damage	Use of abrasive or chemical cleaners
Accident	Modifications	Limescale <sup>**</sup>

<sup>\*\*</sup> If problems result from limescale we will be happy to replace products forwarded to them and a fee will be charged for this service.

Our liability is limited to the repair or replacement of those products supplied and registered only. This guarantee is only valid for products installed within the United Kingdom and the Republic of Ireland.



## TO MAKE A CLAIM

---

To make a claim you must either have:

1. Registered your product with us or be at the address registered on our records;
2. Have dated proof of purchase of the product from one of our registered suppliers, contractors',
3. Acknowledgement of the date on installation and be the original purchaser.

## CONTACT US

---

For support, information or spare parts please email customer services at;

Email: [support@kanth.london](mailto:support@kanth.london)

## TO REGISTER YOUR PRODUCT

---

Please Note: It is important to register your product in order to receive your full guarantee.

Please complete the enclosed registration card, or register your product online at [www.kanth.london](http://www.kanth.london).

Product Serial No.